

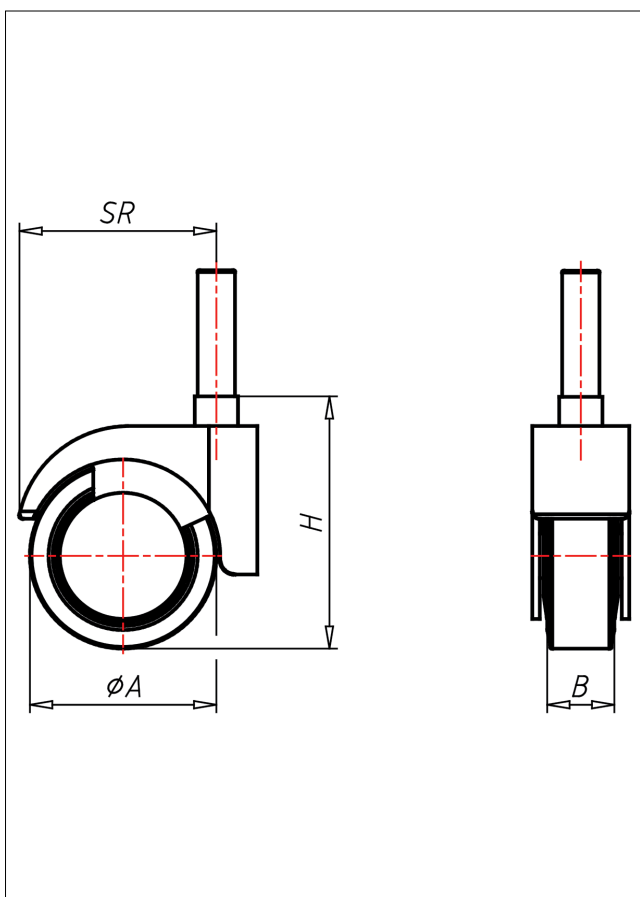

# 475 G

## Lenkrolle

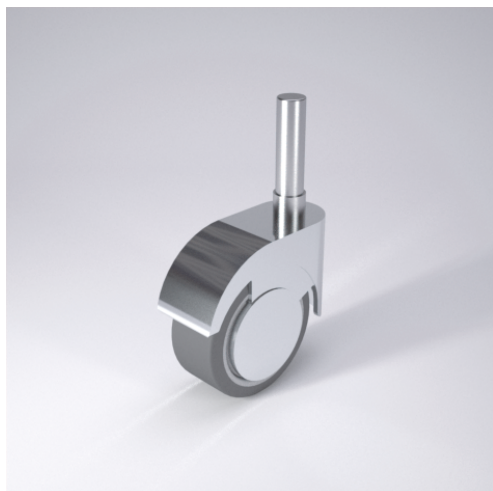

475-G



+60 °C  
-20 °C

max. 40 kg



Gehäuse: Zinkdruckguss - verchromt  
Schwenklager mit kombiniertem  
Gleit-Kugellager  
Felge Polyamid 6  
grauer Gummiereifen - spurfrei  
Radfeststeller glasfaserverstärkt  
Radachse verschraubt

### Technische Details

ORDERNO (Artikel-nummer)	475 10x34 50 G
WDAB (Rad-Ø A x Breite B / mm)	50x18
LC (Tragkraft / kg)	40
H (Bauhöhe H / mm)	68
BOLT (Stift / mm)	10x34
SR (Schwenkradius / mm)	51
WB (Radlager)	Polyamid-Gleitlager